



Automated test solutions for the entire product lifecycle



8-Channel Load Module

Comprehensive load measurement solution

The 8-Channel Load Module provides isolated current and voltage measurements for eight on-board 5W loads or for eight off-board 120W loads. With built-in switching for calibration and fault injection, the module provides unsurpassed capability for mil/aero applications. The module also provides switching and connections to allow switching between a real load (e.g., actuator, valve, etc.) and the simulated load.

When used with on-board loads, standard RH-5 resistors are easily mounted to the module's integrated heatsink and connection points are provided for each load. Built-in current shunts are sized to accommodate the module's $\pm 2A$ current range, and the voltage has selectable ranges of $\pm 60V$, $\pm 30V$, $\pm 20V$ and $\pm 15V$ for a variety of applications. Both voltage and current are isolated to 100 volts. An optional 16-channel load chassis accommodates up to 16 higher-power loads for two load modules. Command and control of chassis-mounted relays (not included) is provided by the SLSC-based load modules

Connectors are standard D-sub connectors and are compatible with other Mil/Aero System Interconnections for SLSC, including SLSC modules from SET and Bloomy, as well as Bloomy's ThroughPoint™ I/O panels and cabling.

This module requires the use of a PXIe-6363 high-density analog input or better.

APPLICATIONS

- Real-time hardware-in-the-loop (HIL)/ closed-loop test systems
- Electronic engine control (EEC) test systems
- Flight control computer (FCC) test systems
- Environmental control test systems

FEATURES

- 8 on-board 5W loads or 8 external 120W loads
- Complete isolation of voltage and current measurements
- Automatic calibration of signal conditioning path using SLSC calibration resources as references
- Optional 1U or 3U load chassis with integrated temperature sensing and remote-controlled fans
- On-board open-circuit fault injection capability
- DC to 160kHz operation
- Minimal 3 μs propagation delay
- $\pm 60V$, $\pm 30V$, $\pm 20V$ and $\pm 15V$ voltage input ranges
- Real/sim switching for all loads

FUNCTIONAL DIAGRAM

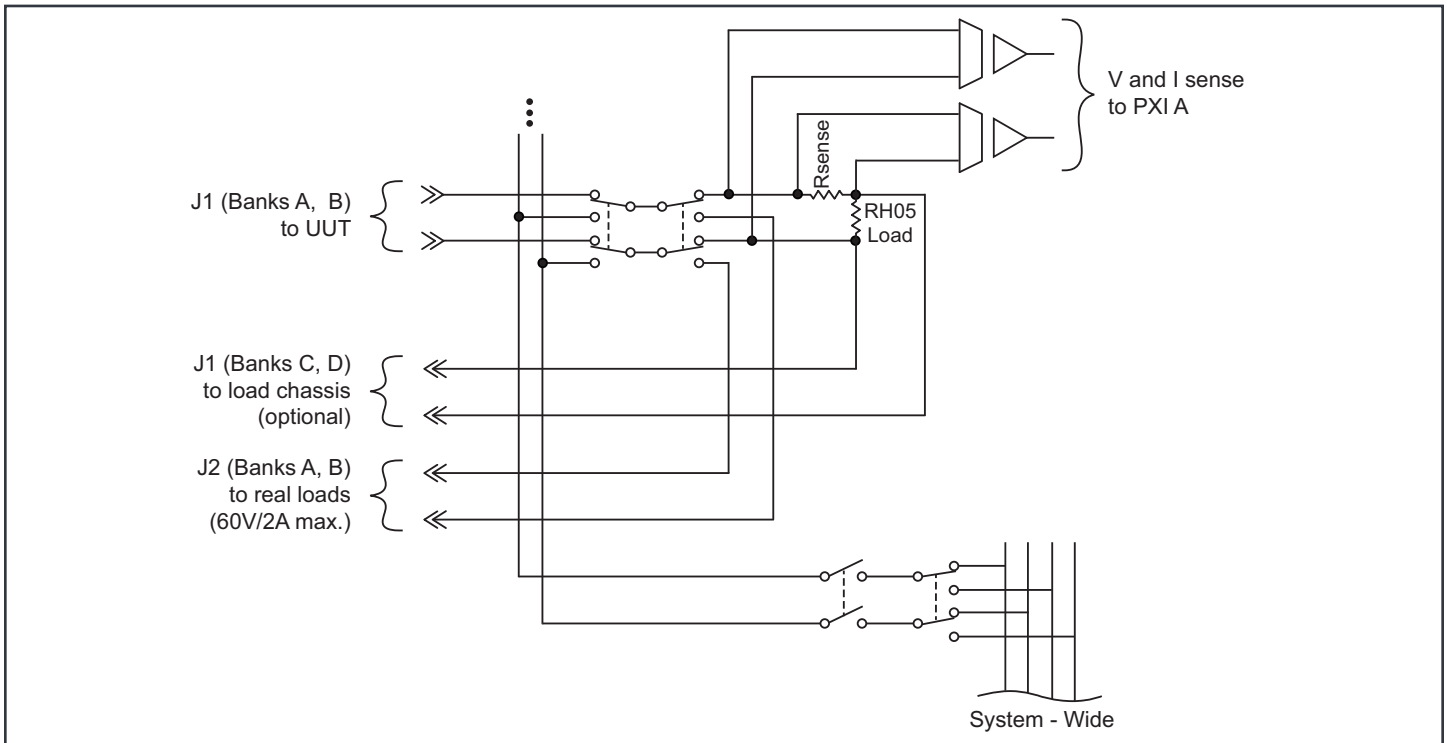

SPECIFICATIONS

INSTRUMENTATION	
Meets National Instruments SLSC Module Specification	
Requires	NI PXIe-6363 (or better)
Channels	8 on-board 5W loads or 8 external 120W loads (optional load chassis required)
Accuracy	0.1% current, $\pm 5\%$ voltage
Bandwidth	DC-160kHz
Range	60V/2A
Connectors	HD44F, DB25F
SOFTWARE	
Software Interface	LabVIEW driver 2015+ VeriStand driver 2015+

ORDERING INFORMATION

PART NUMBER	DESCRIPTION
1200-00029	8-Channel 5W Load Module for SLSC
1200-00035	Remote Load Chassis, 16 channel, 1U, 320W max. dissipation (available Q4 2018)
1200-00024	Remote Load Chassis, 16 channel, 3U, 640W max. dissipation (available Q4 2018)



Call 860-298-9925 or visit
www.bloomy.com