



Automated test solutions for the entire product lifecycle



## BLOOMY® Simulation Reference System

### *Ready-to-use real-time simulation system – customizable for your application*

The Bloomy® Simulation Reference System provides a hardware in-the-loop (HIL) test environment for dynamic, closed-loop testing of many aerospace and transportation control systems. The reference system integrates the computing, I/O, and software components needed for standalone use or to form the basis of a more complex test system.

The system is comprised of standard COTS platform components from NI, BLOOMY, Virginia Panel, and others, and provides all of the critical simulation system elements in a standard rack enclosure.

For applications which require more highly-specialized test systems, the reference system provides a jump start, shortening schedules, reducing costs, and freeing your test engineering departments to focus on the differentiating technologies which make your product unique in the marketplace.

### APPLICATIONS

- FADEC/EEC/Flight Control HIL simulation and test
- Environmental control systems verification and validation
- Development, production, or maintenance testing
- “Fly the Box” test of customer return material
- Development of control laws prior to prototype availability
- Environmental Stress Screening (ESS)/ Highly Accelerated Life Testing (HALT)
- System Integration Labs (SILs)

### FEATURES

- Simulation environment for comprehensive electronic/ electromechanical control testing
- Analog I/O including LVDTs, RVDTs, resolvers, thermocouples, RTDs
- Actuator and indicator loads, including resistive lamps and inductive solenoids and torque motors
- Discrete switch signals, including open/ground, open/Vcc, open/closed
- Simulation-controlled variable DC power supplies; optional 1Ø/3Ø AC supplies
- Available digital communications standards including ARINC-429, MIL-STD-1553B, RS-232/422/485

# SYSTEM BLOCK DIAGRAM

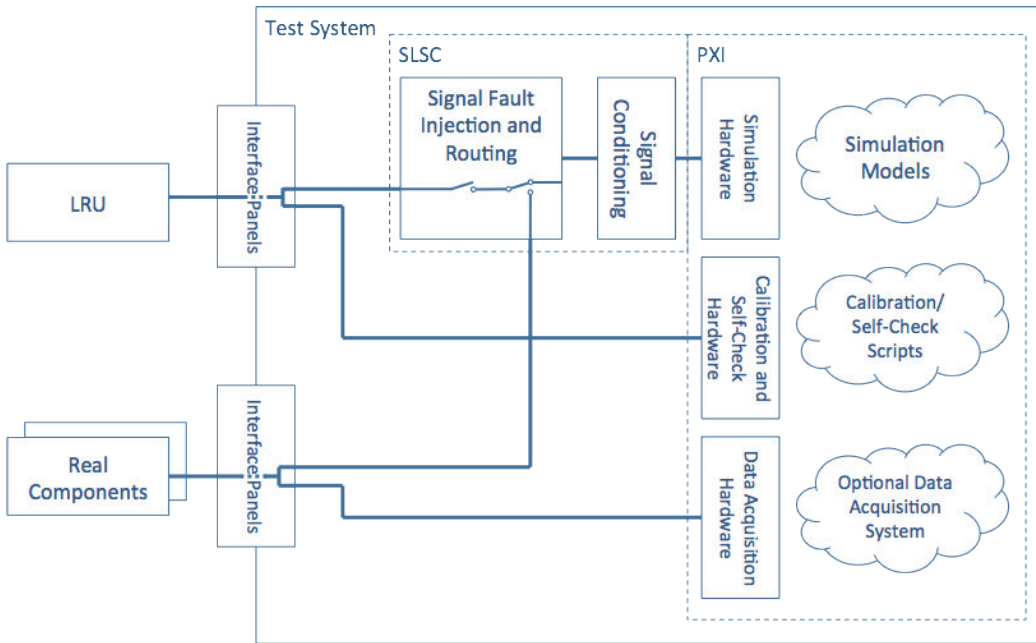

## SPECIFICATIONS

SIGNAL CONDITIONING AND COMMUNICATION I/O	
Interface Type	Channels
VDT/Resolver simulation (4W, 5W, 6W)*	8
Thermocouple simulation*	8
RTD simulation*	8
Thermistor simulation	8
Loads (torque motors, solenoid, lamp, etc.)*	16 (8x <5W, 8x >5W)
Discretes (one-wire and two-wire)	32
Differential analog outputs to UUT	8
Potentiometer/variable resistor simulation	8
RS-422	2
ARINC-429	8
MIL-STD-1553B	Optional
IRIG B	1
Ethernet Test Bus	Optional
DC Power	2
AC Power	Optional
FAULT INSERTION	
*Open circuit fault included.	
Other fault conditions (short to ground, pin to pin short, etc.) optional for all signal types	

COMPUTING RESOURCES	
Real-Time Simulation Host	PXIe-based, RTOS, up to 8-Core Xeon
Instrumentation and System Management	PXIe-based, Windows ick, up to 8-Core Xeon
SOFTWARE ENVIRONMENTS	
Real-time Framework	NI VeriStand
Test Executive	NI TestStand
Data Acquisition and Programming	NI LabVIEW, C/C++
Data Management and Analysis	NI DIAdem
Supported Software Models	C/C++, Simulink, LabVIEW
SYSTEM DIMENSIONS AND POWER	
System Chassis	1- or 2-bay 40U equipment racks
	1-bay: approx. 78"H (w/locking castors) x 23"W x 36"D
	2-bay: approx. 78"H (w/locking castors) x 46"W x 36"D
Weight	Configuration dependent
Power Requirements	Power requirements vary with selected AC and DC power supply options
Emergency Power Off	Standard
Uninterruptible Power Source	Standard for all computing resources
WARRANTY	
1-year warranty on all hardware components, optional extended warranties available	

Call 860-298-9925 or visit  
[www.bloomy.com](http://www.bloomy.com)