

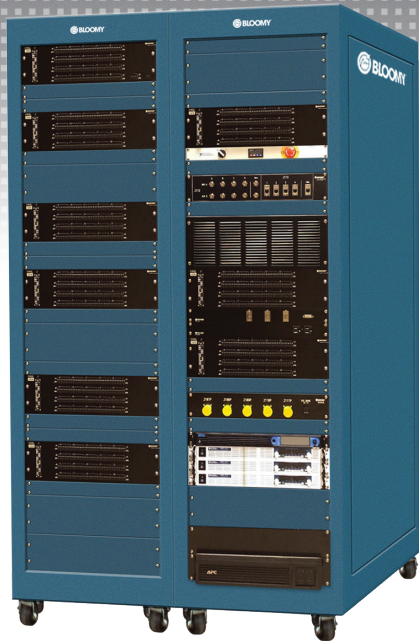

Automated test solutions for the entire product lifecycle



Flight Control System Test Platform

Real-time HIL test of flight control systems for rotary- and fixed-wing aircraft

The Flight Control System Test Platform provides a hardware in-the-loop (HIL) closed-loop test environment for dynamic and maintenance testing of Flight Control Systems (FCS) of both commercial and military aircraft. The system simulates control surface activities from multiple combinations of rudder, flaps, elevator, aileron, and engine controls to the FCS. The system delivers repeatable, cost-effective testing in a fraction of the time needed with typical in-house simulation test systems.

The test system is based upon the Bloomy Simulation Reference System, which reduces overall lifecycle costs and creates a common test platform for HIL test systems in a System Integration Laboratory (SIL). The reference system includes industry-standard components from National Instruments, The MathWorks, Virginia Panel Corporation, and Bloomy. These components are used in other Bloomy Test Platforms including the FADEC/EEC Test Platform and the Environmental Control System Test Platform.

APPLICATIONS

- Flight control system, including, “Fly-by-wire” verification and validation
- Development, production, or maintenance testing
- “Fly the Box” test of customer return material
- Development of control laws prior to airframe test
- Environmental Stress Screening (ESS)/ Highly Accelerated Life Testing (HALT)
- System Integration Labs (SILs)

FEATURES

- Simulation environment for comprehensive flight control system testing
- Analog I/O including thermistor, RTDs, strain gages
- Actuator loads including inductive solenoids, torque motors, and indicator loads
- Discrete switch signals including open/ground, open/Vcc, open/closed
- Available digital communications including ARINC-429, MIL-STD-1553B, FireWire, AFDX, serial
- Simulation-controlled variable DC power supplies; optional 1Ø/3Ø AC supplies
- ThroughPoint™ Interface Panels with integrated breakout box functionality

SYSTEM BLOCK DIAGRAM

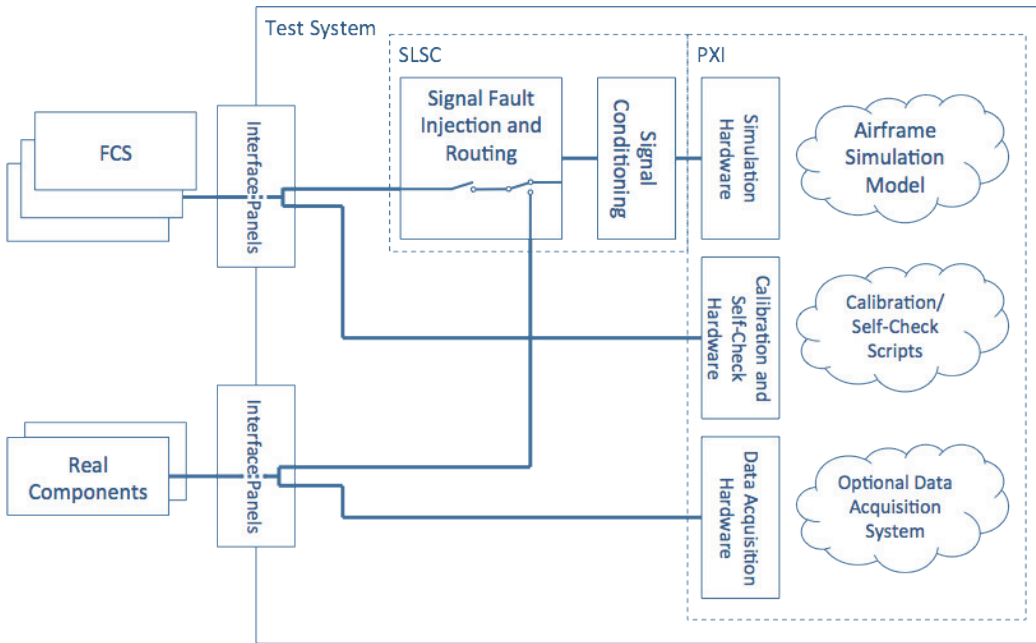

SPECIFICATIONS

SIGNAL CONDITIONING AND COMMUNICATION I/O	
Interface Type	Channels
VDT/Resolver simulation (4W, 5W, 6W)**	8
Thermocouple simulation**	8
RTD simulation**	8
Thermistor simulation*	8
Strain Gauge simulation*	8
Loads (torque motors, solenoid, lamp, etc.)**	16 (8x <5W, 8x >5W)
Discretes (one-wire and two-wire)*	32
Differential analog outputs to UUT*	8
Potentiometer/variable resistor simulation	8
RS-422	2
ARINC-429	8
AFDX/ARINC-664	Optional
MIL-STD-1553B	Optional
IRIG B	1
Ethernet Test Bus	Optional
DC Power	2
AC Power	Optional
FAULT INSERTION	
*Open circuit fault included.	
Other fault conditions (short to ground, pin to pin short, etc.) optional for all signal types	
SELF-TEST	
*Self-test standard, calibration optional	
Loopback self-test optional for all other signal types	

COMPUTING RESOURCES	
Real-Time Simulation Host	PXle-based, RTOS, up to 8-Core Xeon
Instrumentation and System Management	PXle-based, Windows, up to 8-Core Xeon
SOFTWARE ENVIRONMENTS	
Real-time Framework	National Instruments VeriStand
Test Executive	National Instruments TestStand
Data Acquisition and Programming	National Instruments LabVIEW, C/C++
Data Management and Analysis	National Instruments DIAdem
Software Models	23 model types, including LabVIEW, Simulink, Matrix, C/C++, MapleSim
SYSTEM DIMENSIONS AND POWER	
System Chassis	1- or 2-bay 40U equipment racks
	1-bay: approx. 78"H (w/locking castors) x 23"W x 36"D
	2-bay: approx. 78"H (w/locking castors) x 46"W x 36"D
Weight	Configuration dependent
Power Requirements	Power requirements vary with selected AC and DC power supply options
Emergency Power Off	Standard
Uninterruptible Power Source	Standard for all computing resources
WARRANTY	
1-year warranty on all hardware components, optional extended warranties available	
3-year software service plan on all National Instruments software products	

Call 860-298-9925 or visit
www.bloomy.com